



| No | Hardware | Qty. |
|----|---|------|
| 01 | Bolts  Ø6x20 (mm) | 16 |
| 02 | Allen Key  4x57 (mm) | 01 |



A x 2 Legs

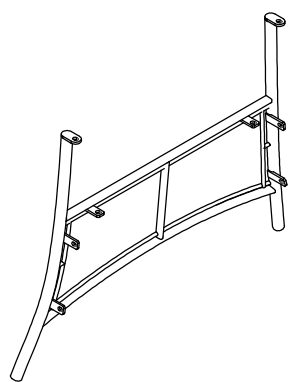
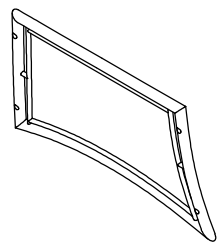

B x 2 Side parts

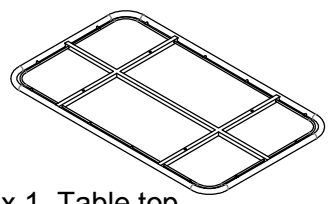

C x 1 Table top

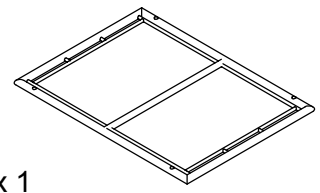

D x 1

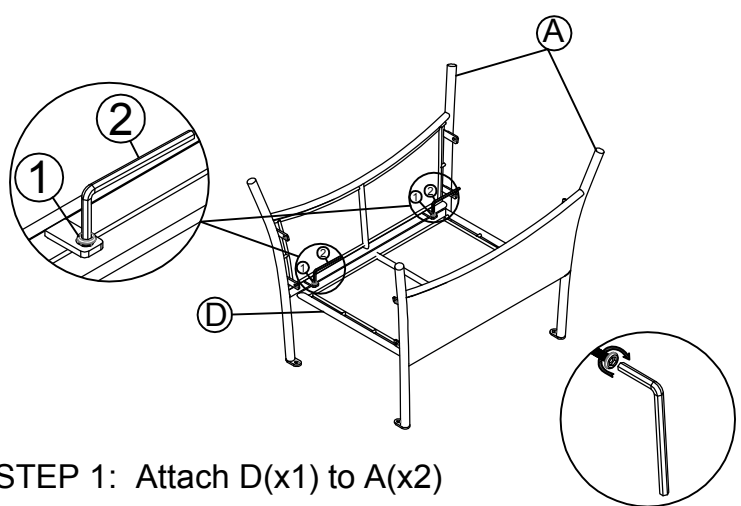
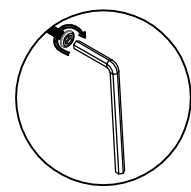

STEP 1: Attach D(x1) to A(x2)

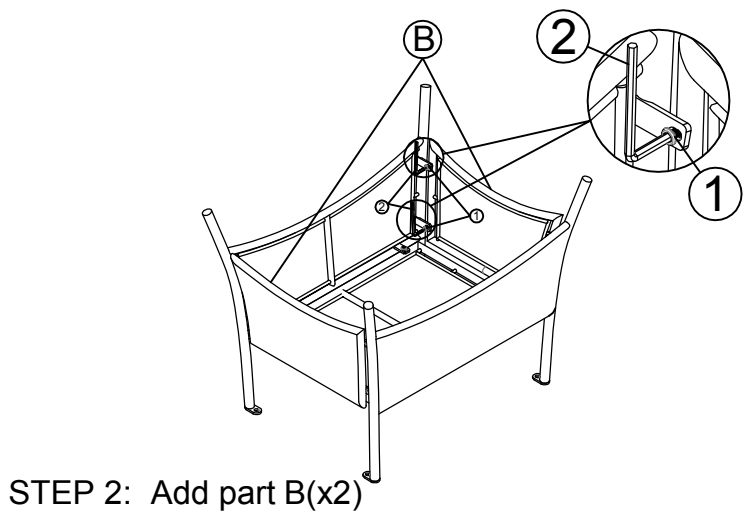

STEP 2: Add part B(x2)

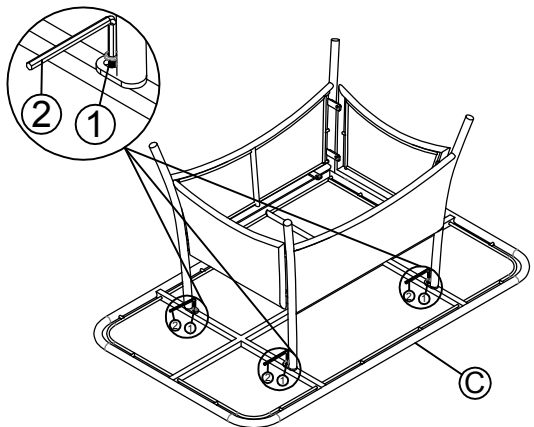

STEP 2: Add part C(x1)

